

S70 / S70A

SOFT SERVE FREEZER

Two Flavor, Floor, Digital Control
A: Pump Feed Model



Most **Powerful** and **Versatile**
Two flavor high capacity floor model
for ice cream, frozen yogurt and
much more

Fast Freeze Down

Patented high efficiency heat exchanger allows fast freeze down with low energy consumption

Digital Control and Display

Microprocessor control provides access to system settings and additional functions. Digital interface displays critical info as system status, temperatures, dispense count, errors, etc.

Auto Programming

Allows automatic switching of operation modes based on preset schedules

Standby

Maintains product temperature in both mix hopper and freezing cylinder below 4.4°C (40°F) overnight

Hopper Agitator

Maintain product consistency and prevent product separation

Ideal for high capacity outlets to serve ice cream, frozen yogurt, gelato or sorbet. Fully loaded with all standard options. Small footprint helps save floor space.



Soft System Start

Slow motor start reduces equipment noise and stress on drive train

Direct Drive Transmission

Eliminates consumable moving parts and increases transmission efficiency

Safety Protections

- Low temperature and motor overload shutoffs to protect in the event of cylinder freeze up
- High pressure switch to prevent compressor overheating

Defrost for Cleaning

Increases efficiency during cleaning by heating frozen product in cylinder

Quick Freeze

Turn on freeze immediately to freeze down to serving viscosity when quick service is required after long idle period

Self-closing Valve with Speed Control

Automatically prevents product overflow after dispense; Provides flexibility in dispense rate control



S70 / S70A

SOFT SERVE FREEZER

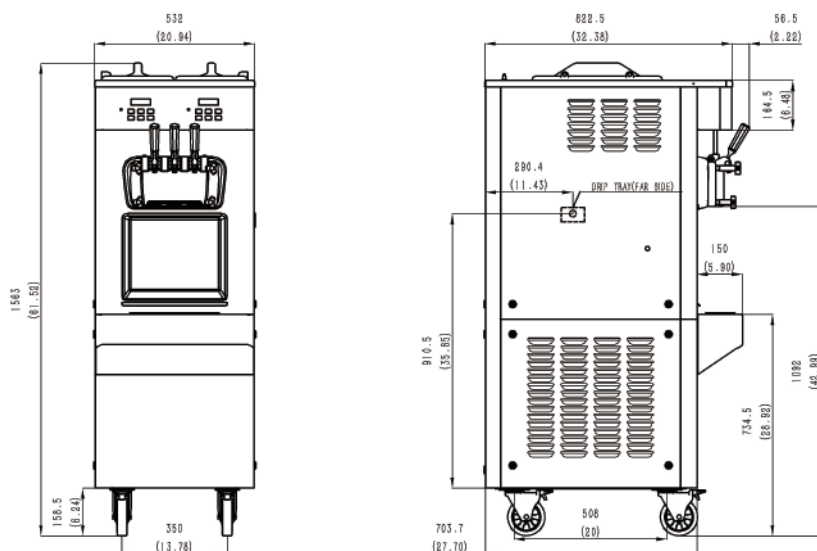

SPECIFICATIONS

Flavors	2 + Twist
Freezing Cylinders	2 x 3.2L / 3.4qt
Mix Hoppers	2 x 15L (10L for A)
Output Capacity (80 grams)	720 serves/hr
Clearance Requirements	152mm/6" on back

Weight

	Kg/lb (Gravity)	Kg/lb (Pump)
Net	253 / 562	263 / 585
Shipping	273 / 607	283 / 629

Volume 1.09 CBM / 38.62 CBF

Dimensions

	Net (mm/in)	Shipping (mm/in)
Width	532 / 20.9	710 / 28.0
Depth	704 / 27.7	890 / 35.0
Height	1563 / 61.5	1730 / 68.1

Electrical

	MFS	MCA	Power(kW)
380-415/50/3	15	11	4.4
208-230/60/3	30	23	4.8
208-230/60/1	30	24	4.9

• 3 Phase

• Above specifications are subject to change without notice

FEATURES

Control Systems Two, Digital

Refrigerated Hoppers	<input checked="" type="checkbox"/>
Hopper Agitators	<input checked="" type="checkbox"/>
Temperature Displays	<input checked="" type="checkbox"/>
Standby Mode	<input checked="" type="checkbox"/>
Auto Closing Dispensing Valves	<input checked="" type="checkbox"/>
Dispensing Speed Control	<input checked="" type="checkbox"/>
Low Mix Indicator Light & Alarm	<input checked="" type="checkbox"/>
Low Temperature Protection	<input checked="" type="checkbox"/>
Motor Overload Protection	<input checked="" type="checkbox"/>
High Pressure Protection	<input checked="" type="checkbox"/>
Defrost & Quick Freeze	<input checked="" type="checkbox"/>
Soft Start	<input checked="" type="checkbox"/>
Direct Drive Pump (A only)	<input checked="" type="checkbox"/>

AVAILABLE OPTIONS

Water Cooled	<input checked="" type="checkbox"/>
Top Air Discharge Chute	<input checked="" type="checkbox"/>