



T29 / T29A

SOFT SERVE FREEZER

Two Flavor, Countertop, Digital Control
A: Pump Feed Model

Simple But Powerful

Classy design that offers quality and simplicity

Fast Freeze Down

Patented high efficiency heat exchanger allows fast freeze down with low energy consumption

Digital Control and Display

Microprocessor control provides access to system settings and additional functions. Digital interface displays critical info as system status, temperatures, dispense count, errors, etc.

Low Mix Indicator

Light turns "ON" at low mix to alert operator to add mix

Self Closing Dispensing Valve

Automatically prevents product overflow after dispense

Dispense Speed Control

Provides flexibility in dispense rate control for different applications

Ideal for medium capacity outlets to add soft serve ice cream and frozen yogurt. Low profile design keeps operation simple and helps reduce cost of ownership.



Standby

Maintains product temperature in both mix hopper and freezing cylinder below 4.4°C (40°F) overnight

Safety Protections

- Low temperature and motor overload shutoffs to protect in the event of cylinder freeze up
- High pressure switch to prevent compressor overheating
- Thermal overload to protect from motor overheating



T29 / T29A

SOFT SERVE FREEZER

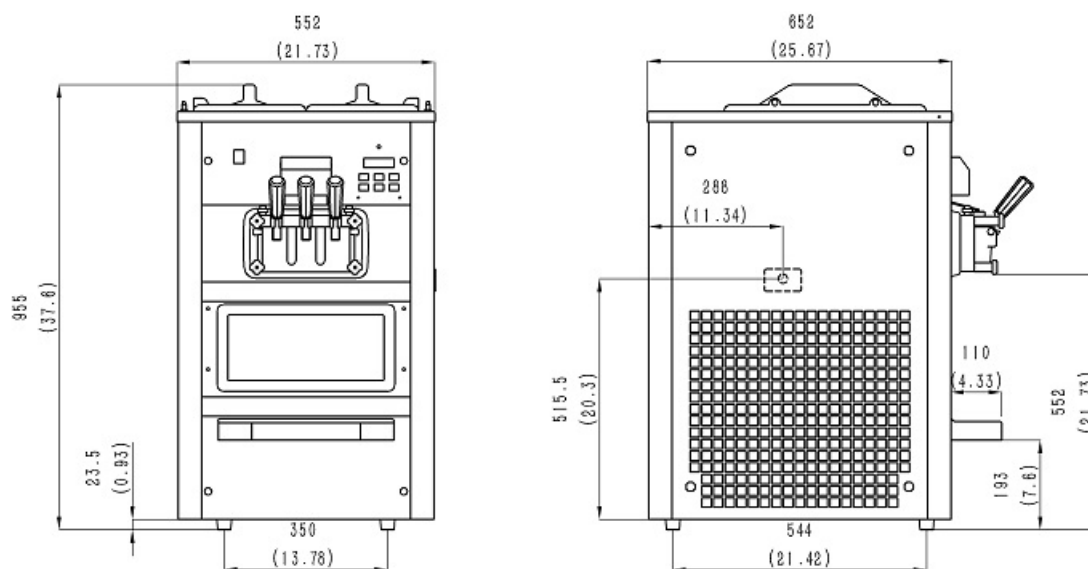

SPECIFICATIONS

Flavors	2 + Twist
Freezing Cylinders	2 x 1.7L / 1.8qt
Mix Hoppers	2 x 12L / 12.7qt
Output Capacity (80 grams)	300 serves/hr
Clearance Requirements	152mm/6" on left

Weight

	Kg/lb (Gravity)	Kg/lb (Pump)
Net	155 / 344	165 / 367
Shipping	170 / 378	180 / 400

Volume 0.57 CBM / 19.97 CBF

Dimensions

	Net (mm/in)	Shipping (mm/in)
Width	552 / 21.7	620 / 24.4
Depth	652 / 25.7	800 / 31.5
Height	955 / 37.6	1140 / 44.9

Electrical

	MFS	MCA	Power(kW)
220-240/50/1	20	15	2.6
208-230/60/1	20	15	2.6

• 16Amp Plug Required

• Above specifications are subject to change without notice

FEATURES

Control Systems Single, Digital

Refrioperated Hoppers

Hopper Agitator

Temperature Display

Standby Mode

Auto Cloising Dispensing Valves

Dispensing Speed Control

Low Mix Indicator Light

Low Mix Indicator Alarm

Low Temperature Protection

Motor Amperage Protection

High Pressure Protection

Thermal Overload Protection

AVAILABLE OPTIONS

Water cooled

Top Air Discharge Chute

Spinner

Soft Start

Custom Branding

Light Box

Remote Auto Fill